

Assembling instructions for Equi Safe fences

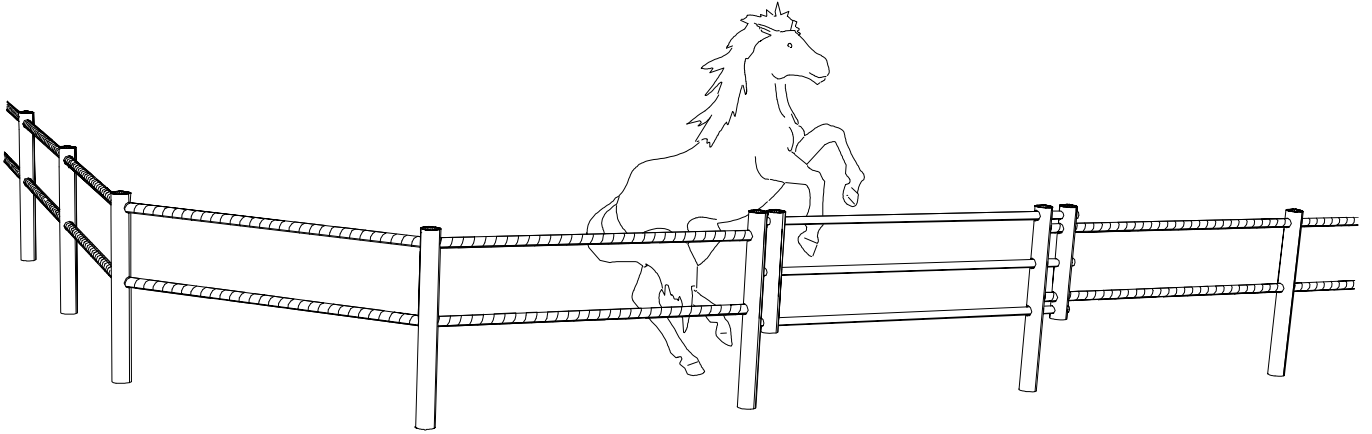

General

- All the posts are mounted with either 167cm or 200cm centre distance.
- The corner posts are drilled with holes for either 90° or 135°, depending on what type of corner it is.
- Gate posts are drilled with 5 holes towards the fence and 3 holes towards the Gate.
- In the case of a double gate, you mount a grounding pipe for the middle post. The grounding pipe is a black pipe with the diameter of 160 mm.
- The middle post is drilled with 3 holes on each side.

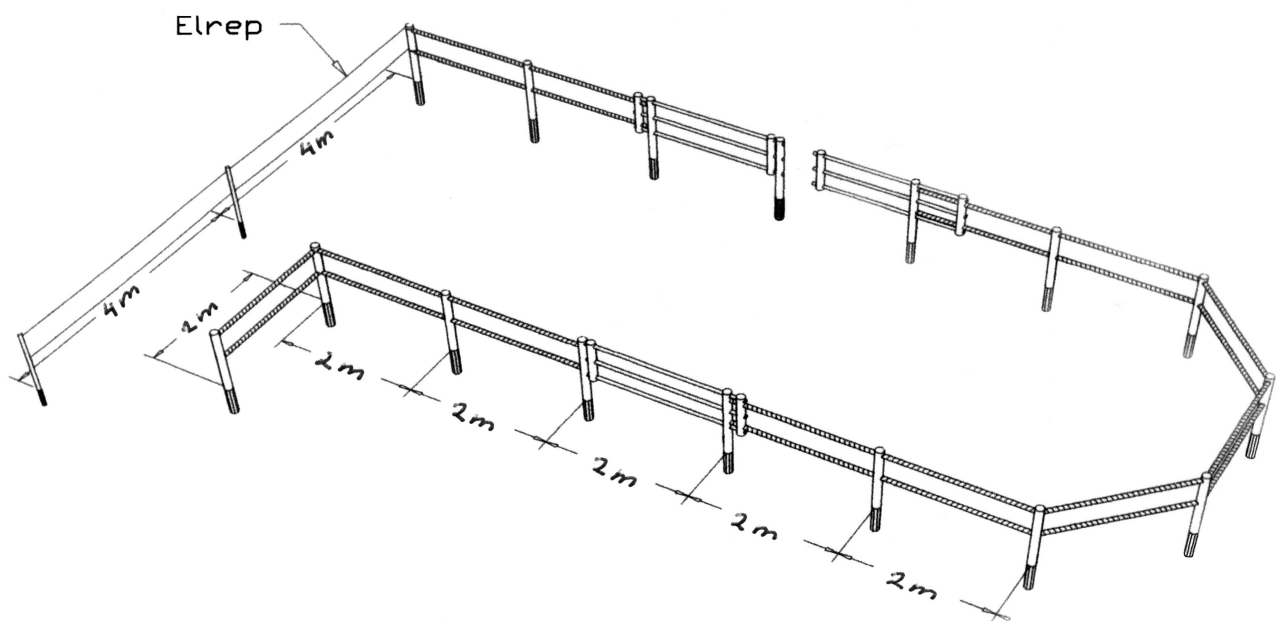

Assembling the Posts

- Use a drill, preferably with the diameter of 200 mm. 150-250 mm are also fine.
- Drill the holes for the corner posts and mount them.

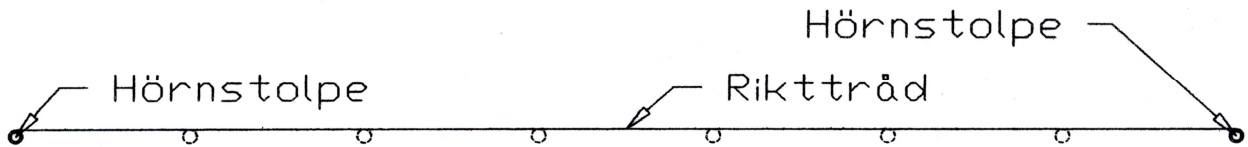

- Take a wire and stretch it between the Corner posts and measure where the holes are supposed to be.
- Drill the other holes.
- Now mount the posts, make sure they are straight and that they are firmly mounted.
- Fill the holes around each post and use a plank to pack the earth tightly. If you do not pack the earth firmly, the fence will go crooked with time.
- Two months after mounting the fence, the posts should be adjusted a final time and the holes filled up.

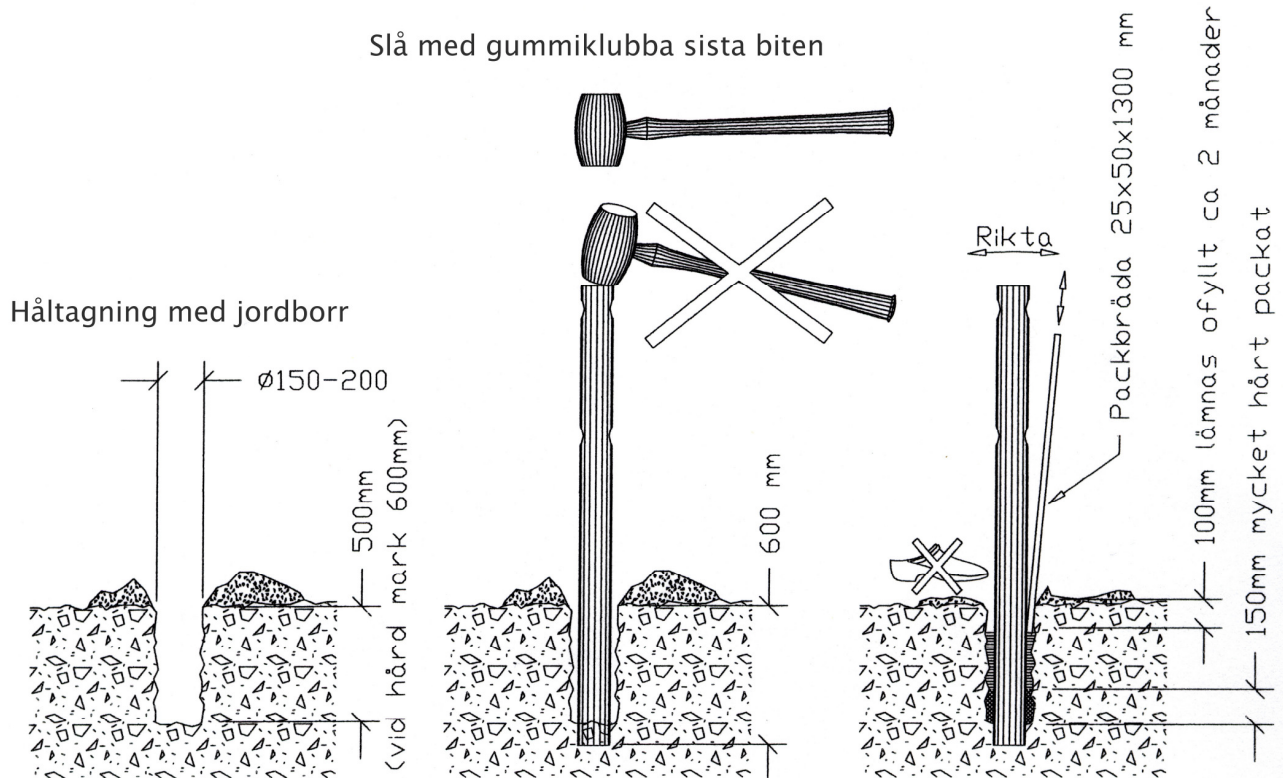

Assembling the rail.

- The rails are delivered 5cm long, and they need to be adjusted as you mount the fence, the reason for this is that you can't always count on that you are able to mount the posts with 167cm or 200cm distance.
- Start mounting the rails in the corner, start with the lower rails. Don't forget to leave about 30mm between each rail, seeing as how they shrink during the winter and expand during the summer.
- If the temperature when you're mounting is over 20°, leave 10-15mm, if it is 0°, leave 15-20mm, and if it is -10°, leave 20-30mm.
- When drilling the holes for the pin, be careful, not to hit the electrical wire.
- A pin extension tool is included, so that you can reach the bottom rail.

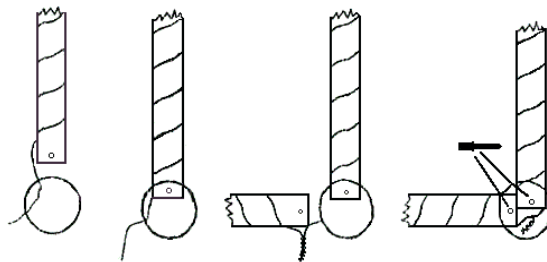

- Unwind the Electrical wire one time; drill a 10mm hole in the rail, 10-15mm from the end of it.
- Pull the electrical wire through the rail, and put the rail into the post.
- Mount the pin into the rail in the post.
- Put a new rail into the next post.
- Unwind the Electrical wire one time; drill a 10mm hole in the rail, 10-15mm from the end of it. Twine the electrical wires together and insert them into the post.
- Put the rail into the post and mount the pin.
- Pull out the rail 10-30mm.
- Combine the electrical wires by an appropriate post between the top and bottom rail with a remaining piece of wire. Do not mix different kinds of metal materials, to avoid oxidation.

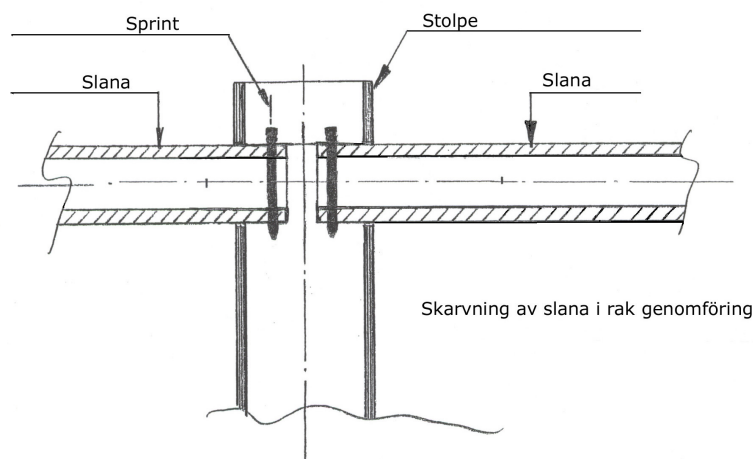

Assembling the Gate

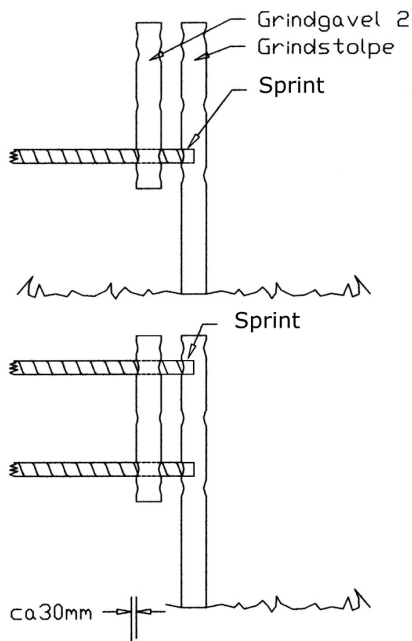

- Connect the second gate gable to the lower rail.
- Attach the lower rail to the gate post.
- Connect the second gate gable to the upper rail.
- Attach the upper rail to the gate post.
- Attach the middle gate-rail to the first gate gable.
- Attach the lower and upper gate-rail to the gate gable.
- Be sure to follow the measurements from the pictures that are included. A 5m long rail can differ in length depending on the temperature. At -20° it will be approximately 30mm shorter than at +30°.
- Attach the upper and lower gate-rails to the second gate gable.
- Make sure all the measurements are correct and that the gate is functional.
- Cut off the rails at the second gate gable.

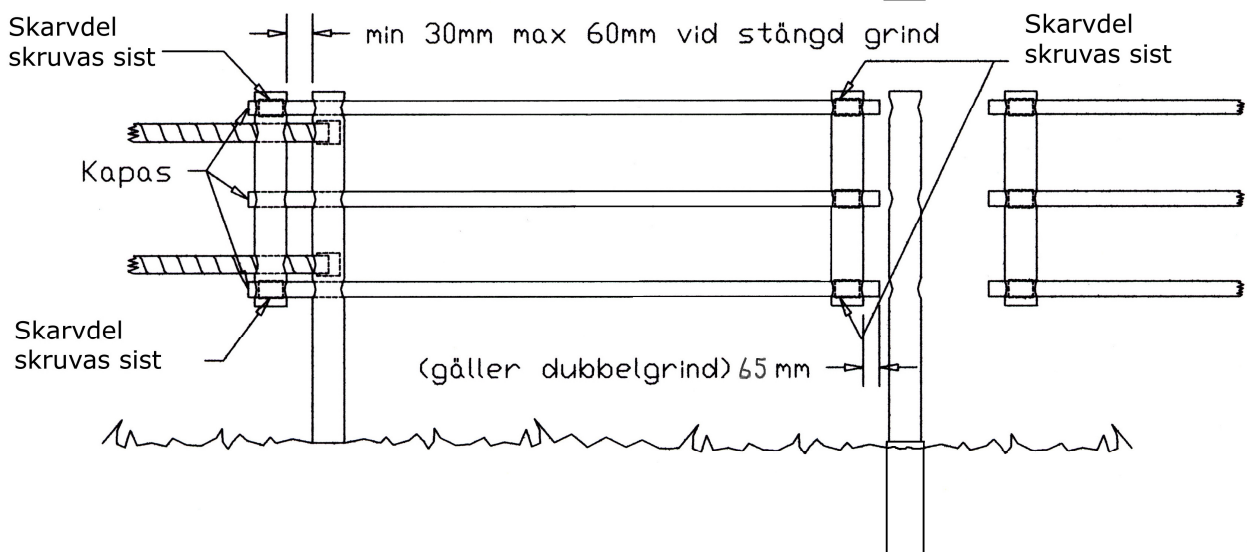
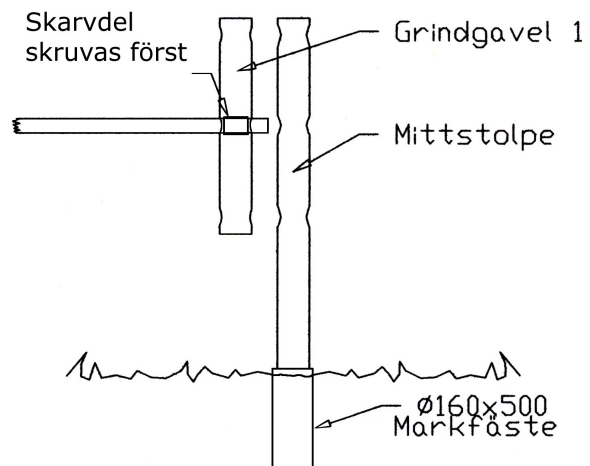
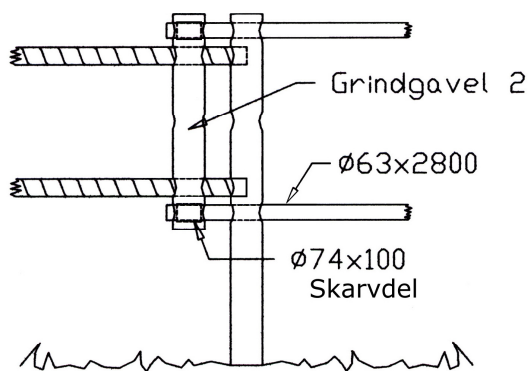

Materials

Equi Safe fences are made of Polyeten HD which possesses great qualities for fences. It won't crack and is resistant against sunlight, weather and wind. If the fence is hit by a vehicle, for example a tractor the posts and rails will bend but can in most cases be bent back into shape, without having to replace any parts.

Maintenance

- Every year the fence needs to be looked after. Correct the posts and check the electricity.
- Turn every rail half-way over to compensate for the natural bending that occurs.
- Wash the fence if needed, to prevent the electricity from grounding.
- Remove objects that close to or in direct contact with the fence, such as plants, branches or grass.
- Make sure there is always electricity in the fence.

Conclusion

Correctly maintained the Equi Safe fences can serve its purpose for many years to come.

Equi Safe Försäljnings AB
Villshäradsvägen 1
310 41 Gullbrandstorp

Tel: +46 35 590 25
Fax: +46 35 535 12